

Registration No :

--	--	--	--	--	--	--	--	--	--

Total Number of Pages: 02

B.Tech.  
PET51102

5<sup>th</sup> Semester Regular / Back Examination 2017-18  
Digital Signal Processing

BRANCH: ECE, ETC

Time: 3 Hours

Max Marks: 100

Q.CODE: B456

Answer Question No.1 and 2 which are compulsory and any four from the rest.  
The figures in the right hand margin indicate marks.

**Q1 Answer the following questions: *multiple type or dash fill up type* (2 x 10)**

- (ROC) Region of convergence of  $x(n) = \delta(n)$  is \_\_\_\_\_.
- If  $Z[x(n)] = X(z)$ , then  $Z[a^n x(n)] =$  \_\_\_\_\_.
- The number of arithmetic operations (multiplications and additions) required to compute the output of a system is called \_\_\_\_\_ of that system.
- \_\_\_\_\_ filters are preferred in filtering problems where there is a requirement of linear phase characteristics in the passband of filter.
- IIR filter has lower \_\_\_\_\_ in the stopband than FIR filter having same number of parameters.
- To compute N point DFT, it requires \_\_\_\_\_ complex multiplications and \_\_\_\_\_ complex additions.
- FFT is an efficient way of finding \_\_\_\_\_.
- Adaptive filter is an example of \_\_\_\_\_ system. (open loop/ closed loop)
- \_\_\_\_\_ band lies in between passband & stopband of the filter characteristics.
- In an adaptive filter, \_\_\_\_\_ of the filter are made to adapt to signal statistics.

**Q2 Answer the following questions : Short answer type (2 x 10)**

- What is the condition on the ROC of the system function for stability of an LTI system?
- What do you understand by a causal LTI system?
- The first five points of the eight-point DFT of a real valued sequence are  $\{0.25, 0.125-j0.3018, 0, 0.125-j0.0518, 0\}$ . Determine the remaining three points.
- Give the difference equation and system function expression for an FIR system.
- Draw a direct form realisation for the filter with impulse response:  
$$h(n) = \{1, 2, 3, 4, 3, 2, 1\}$$
- State the *Time Reversal Property* in DFT.
- What is N in N-point DFT?
- What do you understand by radix of an FFT algorithm?
- What is meant by linear phase characteristic of a filter?
- What is BIBO in reference to stability of a system?

**Q3 a) Determine the inverse z-transform of  $X(z) = \frac{1}{1-1.5z^{-1}+0.5z^{-2}}$ , when (10)**

ROC:  $|z| > 1$   
ROC:  $|z| < 0.5$

**b) An LTI system is characterised by the system function  $(z) = \frac{3-4z^{-1}}{1-3.5z^{-1}+1.5z^{-2}}$ . (5)**

Specify the ROC of  $H(z)$ , when the system is:

Stable  
Causal  
Anticausal

- Q4 a)** Prove that the multiplication of two DFTs is equivalent to circular convolution of their respective time domain sequences. **(10)**
- b)** Perform the circular convolution of the following two sequences: **(5)**  
 $x_1(n) = \{2, 1, 2, 1\}$  &  $x_2(n) = \{1, 2, 3, 4\}$  using the time domain formula.

- Q5 a)** Obtain the direct form-I, direct form II, cascade and parallel structures for the system represented by the difference equation: **(10)**

$$y(n] = \frac{3}{4}y(n-1) - \frac{1}{8}y(n-2) + x(n) + \frac{1}{3}x(n-1)$$

- b)** Determine the system function and impulse response of the system shown in the figure: **(5)**

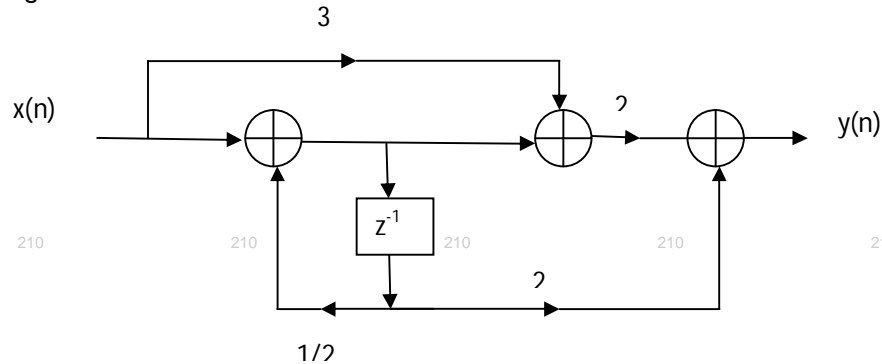

- Q6 a)** Compute the eight point DFT of the sequence  $x(n) = \{0.5, 0.5, 0.5, 0.5, 0, 0, 0, 0\}$  using the in-place radix-2 decimation in time algorithm. **(10)**
- b)** Give the expressions for directly calculating the DFT and IDFT. What are the *symmetry property* and *periodicity property* of phase factor  $W_N$  in context to finding DFT. Discuss the need and feasibility of efficient algorithms for finding DFT. **(5)**
- Q7 a)** With supporting block diagram and mathematical expressions, explain what is channel equalisation and how it can be realised with adaptive filters. **(10)**
- b)** Explain LMS algorithm in terms of gradient descent and recursion with supporting mathematical expressions. **(5)**
- Q8 a)** Derive the *Wiener Hopf* equation based on minimum mean square error. **(10)**
- b)** State the orthogonality principle in mean-square estimation? Give the mathematical expression and emphasise its significance. **(5)**
- Q9 a)** Compute the convolution of the following signals by means of z-transform: **(10)**

$$x_1(n) = \begin{cases} \left(\frac{1}{3}\right)^n, & n \geq 0 \\ \left(\frac{1}{2}\right)^n, & n < 0 \end{cases}$$

$$x_2(n) = \left(\frac{1}{2}\right)^n u(n)$$

- b)** Use the convolution property to express the z-transform of: **(5)**

$$y(n) = \sum_{k=-\infty}^n x(k)$$